

Frequency detector design project

Circuits II

Seattle Pacific University

Name: Oscar Lopez

Date: March 5, 2026

Circuit description

The 25 kHz frequency detector circuit is composed of three primary functional stages: an active bandpass filter, an envelope peak detector, and a voltage comparator.

The first functional block of the circuit utilizes an 8th-order cascaded Sallen-Key bandpass filter topology. This active filter is built using four cascaded 2nd-order stages, designed with a center frequency f_0 of 25 kHz to isolate the target signal while actively attenuating adjacent frequencies (such as the 10 kHz and 17 kHz signals from other transmitters). The overall 8th-order design provides a steep roll-off to ensure strict frequency isolation.

The filtered AC signal is then fed into a peak detector. This stage acts as an envelope detector, utilizing two diodes and an RC circuit ($\tau = 4$ ms) to rectify the AC signal and hold its peak voltage. This converts the high-frequency 25 kHz oscillation into a stable, readable DC voltage V_{peak} .

Finally, the DC output from the peak detector enters an LM339 comparator. The comparator evaluates V_{peak} against a fixed 1.0V reference voltage V_{ref} generated by a voltage divider. When the 25 kHz signal is present, V_{peak} exceeds the 1.0V threshold, causing the LM339's open-collector output to transition to a HIGH state (5V), allowing current to flow through the series resistor and illuminate the indicator LED.

Design: 8th-order (Cascaded Sallen-Key)

General Base Calculations

For the Sallen-Key bandpass filter design, the base resistor value R and its double $2R$ are calculated using the target center frequency f_0 and the chosen capacitor value C . These base values are consistent across all stages.

$$f_0 = 25 \text{ kHz}, C = 15 \text{ nF} = 15 \cdot 10^{-9} \text{ F}$$

$$R = \frac{1}{2\pi f_0 C} = \frac{1}{2\pi(25k)(15 \cdot 10^{-9})} = 424.4\Omega$$

$$2R = 2 \cdot 424.4 = 848.8\Omega$$

Stage-by-Stage Component Design and Recalculation

For each stage, the Quality Factor Q , the amplifier input resistor R_g , and the theoretical voltage divider ratio b are chosen. From these, the required amplifier gain A , feedback resistor R_f , and voltage divider resistors R_a and R_b are calculated. Standard resistor values are then selected, and the exact b value and stage gain $G_{V/V}$ are recalculated.

The theoretical formulas used for all stages are:

$$A = 3 - \frac{1}{Q}$$

$$R_f = R_g(A - 1)$$

$$R_a = \frac{R}{b}$$

$$R_b = \frac{R}{1 - b}$$

Stage 1 Design

Parameters: $Q_1 = 1$, $R_{g1} = 10k$, $b_1 = 0.36$

$$A_1 = 3 - \frac{1}{1} = 2.0$$

$$R_{f1} = 10000(2.0 - 1) = 10k\Omega$$

$$R_{a1} = \frac{424.4}{0.36} \approx 1178.9 \rightarrow 1.2\Omega \text{ (standard resistor)}$$

$$R_{b1} = \frac{424.41}{1 - 0.36} = 663 \rightarrow 680\Omega \text{ (standard resistor)}$$

$$\text{Actual } b \text{ and Gain: } b_1 = \frac{680}{1200+680} = 0.3617$$

$$G_1 = b_1 \cdot A_1 \cdot Q_1 = 0.3617 \cdot 2.0 \cdot 1.0 = 0.7234 \frac{V}{V}$$

Stage 2 Design

Parameters: $Q_2 = 4$, $R_{g2} = 10 k$, $b_2 = 0.24$

$$A_2 = 3 - \frac{1}{4} = 2.75$$

$$R_{f2} = 10000(2.75 - 1) = 17.5 k\Omega$$

$$R_{a2} = \frac{424.41}{0.24} = 1768.3 \rightarrow 1.8 \Omega \text{ (standard resistor)}$$

$$R_{b2} = \frac{424.41}{1 - 0.24} = 558.4 \rightarrow 560 \Omega \text{ (standard resistor)}$$

$$\text{Actual } b \text{ and Gain: } b_2 = \frac{560}{1800+560} = 0.2373$$

$$G_2 = b_2 \cdot A_2 \cdot Q_2 = 0.2373 \cdot 2.75 \cdot 4.0 = 2.6103 \frac{V}{V}$$

Stage 3 Design

Parameters: $Q_3 = 2$, $R_{g3} = 10 k$, $b_3 = 0.24$

$$A_3 = 3 - \frac{1}{2} = 2.5$$

$$R_{f3} = 10000(2.5 - 1) = 15 k\Omega$$

$$R_{a3} = \frac{424.41}{0.24} = 1768.3 \rightarrow 1.8 k\Omega \text{ (standard resistor)}$$

$$R_{b3} = \frac{424.41}{1 - 0.24} = 558.4 \rightarrow 560 \Omega \text{ (standard resistor)}$$

$$\text{Actual } b \text{ and Gain: } b_3 = \frac{560}{1800+560} = 0.2373$$

$$G_3 = b_3 \cdot A_3 \cdot Q_3 = 0.2373 \cdot 2.5 \cdot 2.0 = 1.1865 \frac{V}{V}$$

Stage 4 Design

Parameters: $Q_4 = 2$, $R_{g4} = 10 k$, $b_4 = 0.24$

$$A_4 = 3 - \frac{1}{2} = 2.5$$

$$R_{f4} = 10000(2.5 - 1) = 15 k\Omega$$

$$R_{a4} = \frac{424.41}{0.24} = 1768.3 \rightarrow 1.8 k\Omega \text{ (standard resistor)}$$

$$R_{b4} = \frac{424.41}{1 - 0.24} = 558.4 \rightarrow 560 \Omega \text{ (standard resistor)}$$

Actual b and Gain:

$$b_4 = \frac{560}{1800+560} = 0.2373$$

$$G_4 = b_4 \cdot A_4 \cdot Q_4 = 0.2373 \cdot 2.5 \cdot 2.0 = 1.1865 \frac{V}{V}$$

Total System Gain

The total cascaded linear gain is the product of the individual stage gains.

$$G_{total} = G_1 \cdot G_2 \cdot G_3 \cdot G_4$$

$$G_{total} = 0.7234 \cdot 2.6103 \cdot 1.1865 \cdot 1.1865 = 2.658 \frac{V}{V}$$

Total theoretical linear gain into decibels:

$$Gain_{dB} = 20 \log_{10}(G_{total}) = 20 \log_{10}(2.658) = 8.49 \text{ dB}$$

Transfer Function Equation

$$H_{total}(s) = H_1(s) \cdot H_2(s) \cdot H_3(s) \cdot H_4(s)$$

$$H_{total}(s) = \prod_{i=1}^4 \left[\frac{\left(\frac{b_i \cdot A_i \cdot Q_i \cdot \omega_0}{Q_i} \right) s}{s^2 + \left(\frac{\omega_0}{Q_i} \right) s + \omega_0^2} \right]$$

Peak Detector Design

The peak detector is designed to hold the peak voltage of the filtered signal. The time constant tau is selected to be 100 times the period T of the target 25 kHz signal to ensure a stable DC output with minimal decay between cycles.

Parameters:

$$f = 25 \text{ kHz}$$

$$C = 100 \text{ nF} = 100 \cdot 10^{-9} \text{ F}$$

$$T = \frac{1}{25000} = 4 \cdot 10^{-6}$$

$$\tau = T \cdot 100 = 4 \cdot 10^{-3}$$

$$R = \frac{\tau}{C} = \frac{0.004}{100 \cdot 10^{-9}} = 40 \text{ k}\Omega$$

Comparator Stage Design

The comparator uses a voltage divider consisting of R_3 and R_4 to set the required 1.0V reference voltage from the 5V supply.

$$V_{CC} = 5V$$

$$V_{ref} = 1.0V$$

$$R_4 = 1 \text{ k}\Omega$$

$$V_{ref} = V_{CC} \cdot \left(\frac{R_4}{R_3 + R_4} \right)$$

$$1.0 = 5 \cdot \left(\frac{1000}{R_3 + 1000} \right)$$

$$R_3 + 1000 = \frac{5000}{1.0} = 4 \text{ k}\Omega$$

LED $V_L = 2V$ (Typical for blue or white)

$$V_{CC} = 5V$$

$$V_L = 2V$$

$$I = 15 \text{ mA}$$

$$R = \frac{V_{CC} - V_L}{I} = \frac{5 - 2}{0.015} = 200 \Omega$$

Resistor used: $R = 220 \Omega$ (13.6mA)

MATLAB code:

```
s = tf('s');
f0 = 25000;
w0 = 2 * pi * f0;

% Stage 1 Parameters
A_s1 = 2.0;
Q_s1 = 1.0;
b_s1 = 0.3617;

% Stage 2 Parameters
A_s2 = 2.75;
Q_s2 = 4.0;
b_s2 = 0.2373;

% Stage 3 Parameters
A_s3 = 2.5;
Q_s3 = 2.0;
b_s3 = 0.2373;

% Stage 4 Parameters
A_s4 = 2.5;
Q_s4 = 2.0;
b_s4 = 0.2373;

% Transfer Functions
H1 = ( (b_s1 * A_s1 * Q_s1 * w0) / Q_s1 * s ) / (s^2 + (w0/Q_s1)*s + w0^2);
H2 = ( (b_s2 * A_s2 * Q_s2 * w0) / Q_s2 * s ) / (s^2 + (w0/Q_s2)*s + w0^2);
H3 = ( (b_s3 * A_s3 * Q_s3 * w0) / Q_s3 * s ) / (s^2 + (w0/Q_s3)*s + w0^2);
H4 = ( (b_s4 * A_s4 * Q_s4 * w0) / Q_s4 * s ) / (s^2 + (w0/Q_s4)*s + w0^2);

% Total Cascaded Transfer Function
H_total = H1 * H2 * H3 * H4;
bode(H_total)
```

Results & Verification

| Stage | Quality Factor (Q) | Amplifier Gain (A) | Divider (b) | Stage Gain (V/V) | Stage Gain (dB) |
|--------------|--------------------|--------------------|-------------|------------------|-----------------|
| Stage 1 | 1 | 2 | 0.3617 | 0.723 V/V | -2.81 dB |
| Stage 2 | 4 | 2.75 | 0.2373 | 2.610 V/V | 8.33 dB |
| Stage 3 | 2 | 2.5 | 0.2373 | 1.187 V/V | 1.49 dB |
| Stage 4 | 2 | 2.5 | 0.2373 | 1.187 V/V | 1.49 dB |
| Total System | -- | -- | -- | 2.658 V/V | 8.49 dB |

| Parameter | MATLAB Theory | LTspice Simulation S4 | Measured Lab Stage 4 | Gain |
|--------------------|---------------|-------------------------------|------------------------------|-----------|
| Peak Gain at 25kHz | 8.34 dB | 8.69 dB | 12.25 dB | 4.09 V/V |
| Gain at 17 kHz | -14.7 dB | -14.52 dB (Diff: -23.22dB) | -15.45 dB (Diff: -27.7dB) | 0.168 V/V |

LTspice Diagram 8th-order (Cascaded Sallen-Key)

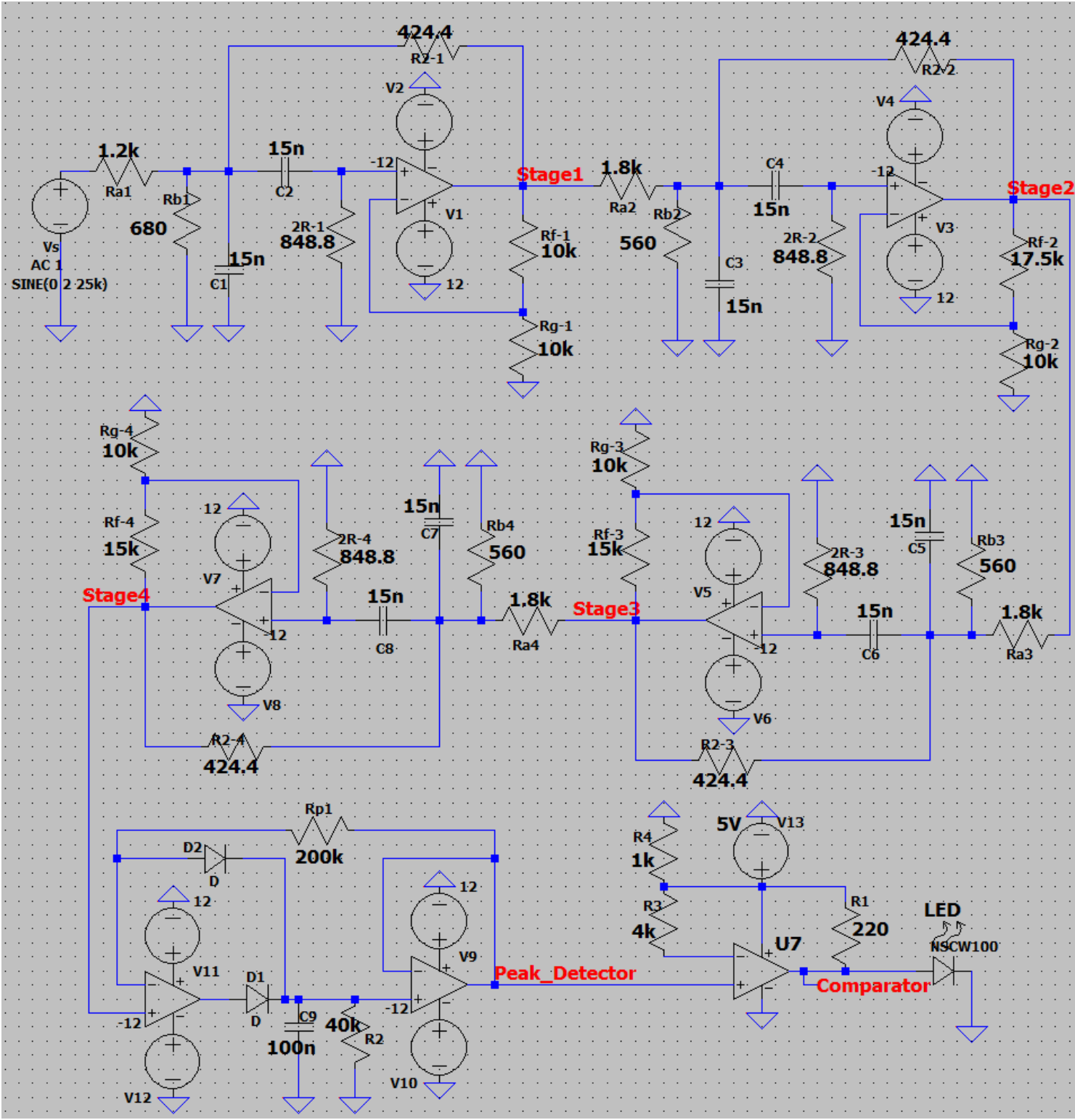

LTspice Bode Plot at 25 kHz

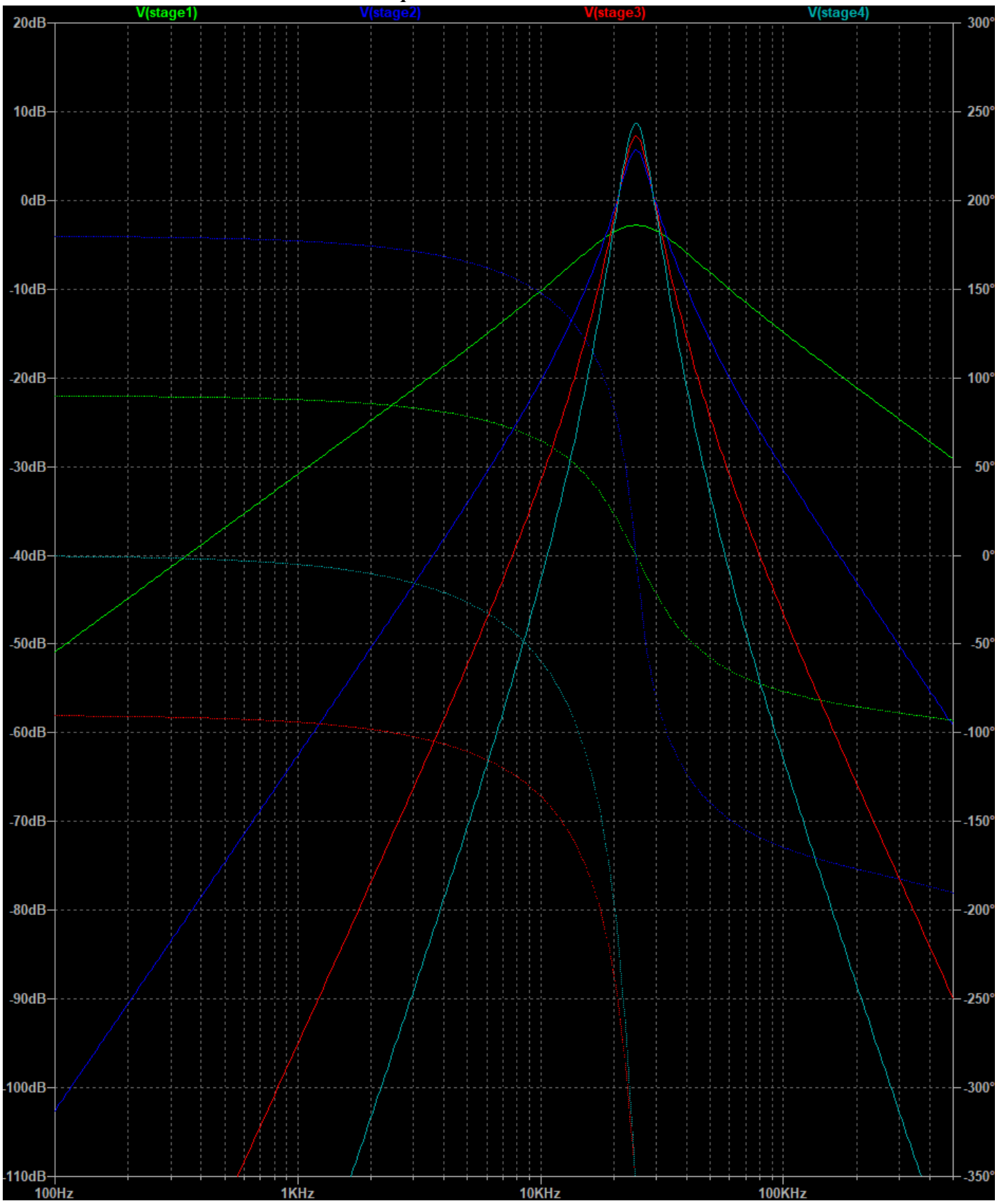

MATLAB Bode Plot (25 kHz, 17 kHz, 10 kHz)

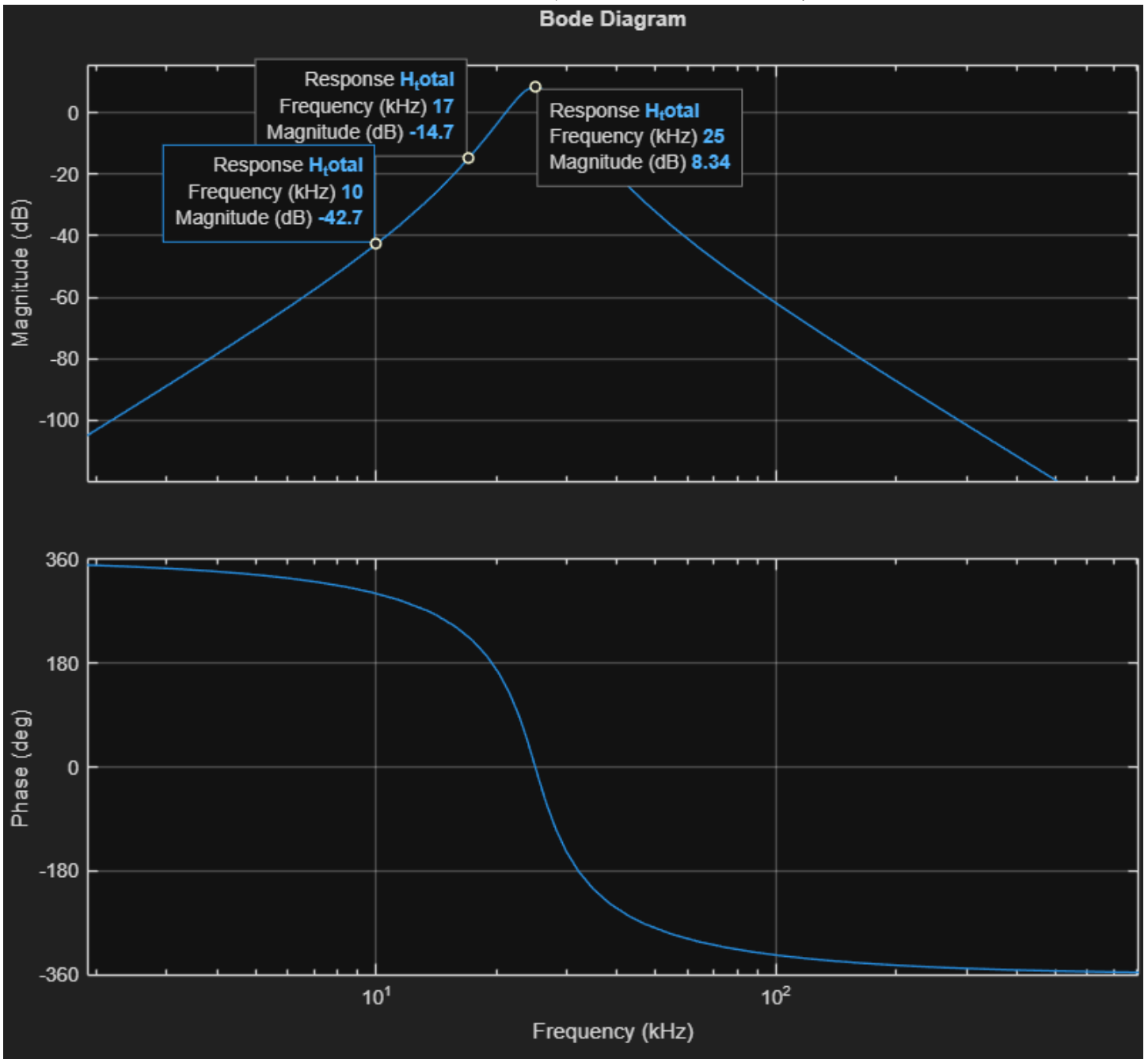

Bandpass Sallen Key lab 25kHz(rev3)Exper... X

Cursor 1

V(stage4)

Freq: 25.008492KHz Mag: 8.6978342dB

Phase: -372.6736°

Group Delay: 116.49247μs

Cursor 2

V(stage4)

Freq: 17.005617KHz Mag: -14.522811dB

Phase: -135.43026°

Group Delay: 44.014264μs

Ratio (Cursor2 / Cursor1)

Freq: -8.0028751KHz Mag: -23.220645dB

Phase: -122.75665°

Group Delay: -72.478205μs

Bandpass Sallen Key lab 25kHz(rev3)Exper... X

Cursor 1

V(stage4)

Freq: 25.007805KHz Mag: 8.6978699dB

Phase: -372.64453°

Group Delay: 116.49871μs

Cursor 2

V(stage4)

Freq: 10.041429KHz Mag: -42.636517dB

Phase: -59.485231°

Group Delay: 21.246559μs

Ratio (Cursor2 / Cursor1)

Freq: -14.966376KHz Mag: -51.334387dB

Phase: -46.840699°

Group Delay: -95.252155μs

FRA Bode Plot at 25 kHz

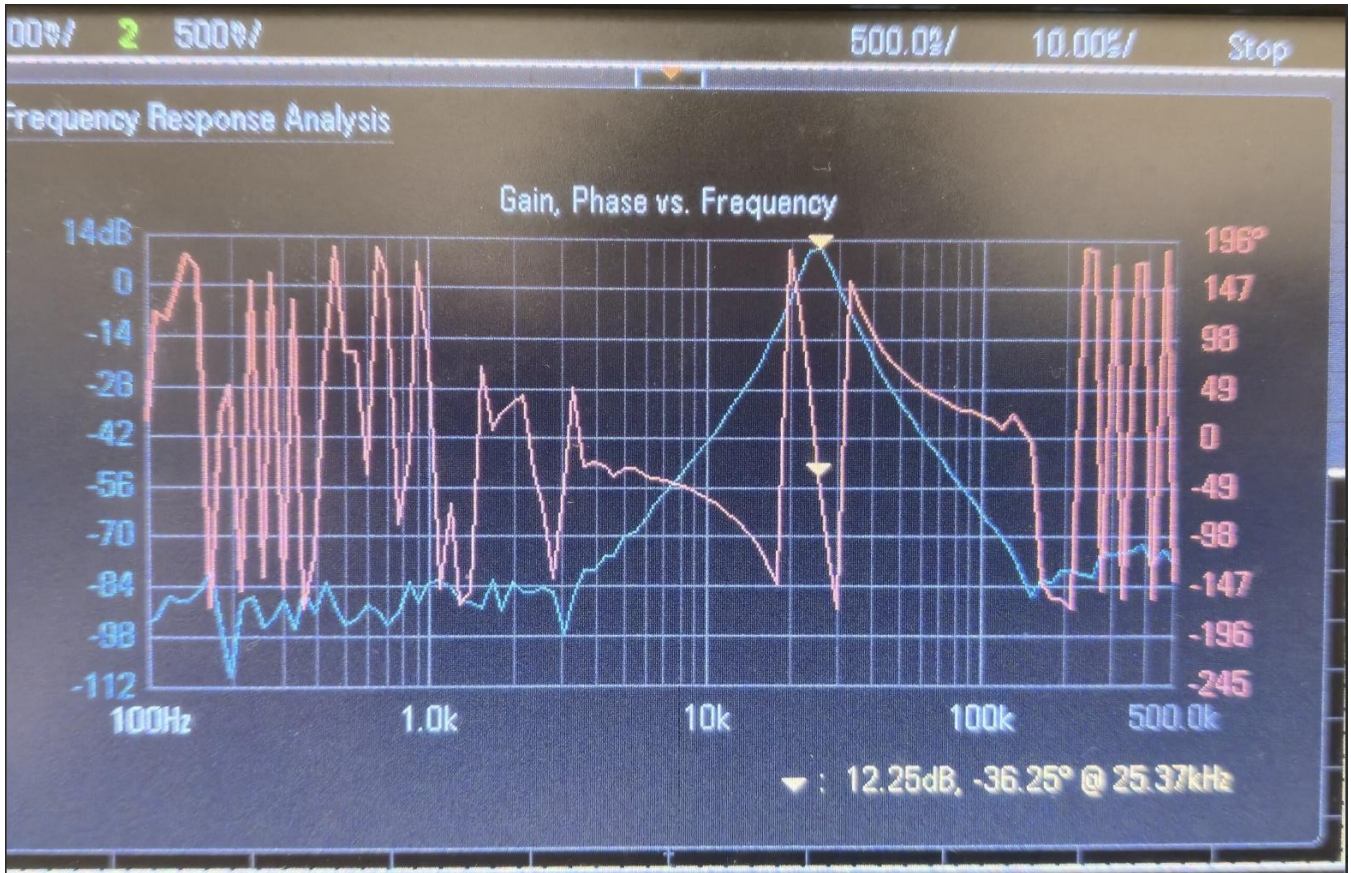

FRA Bode Plot at 17 kHz

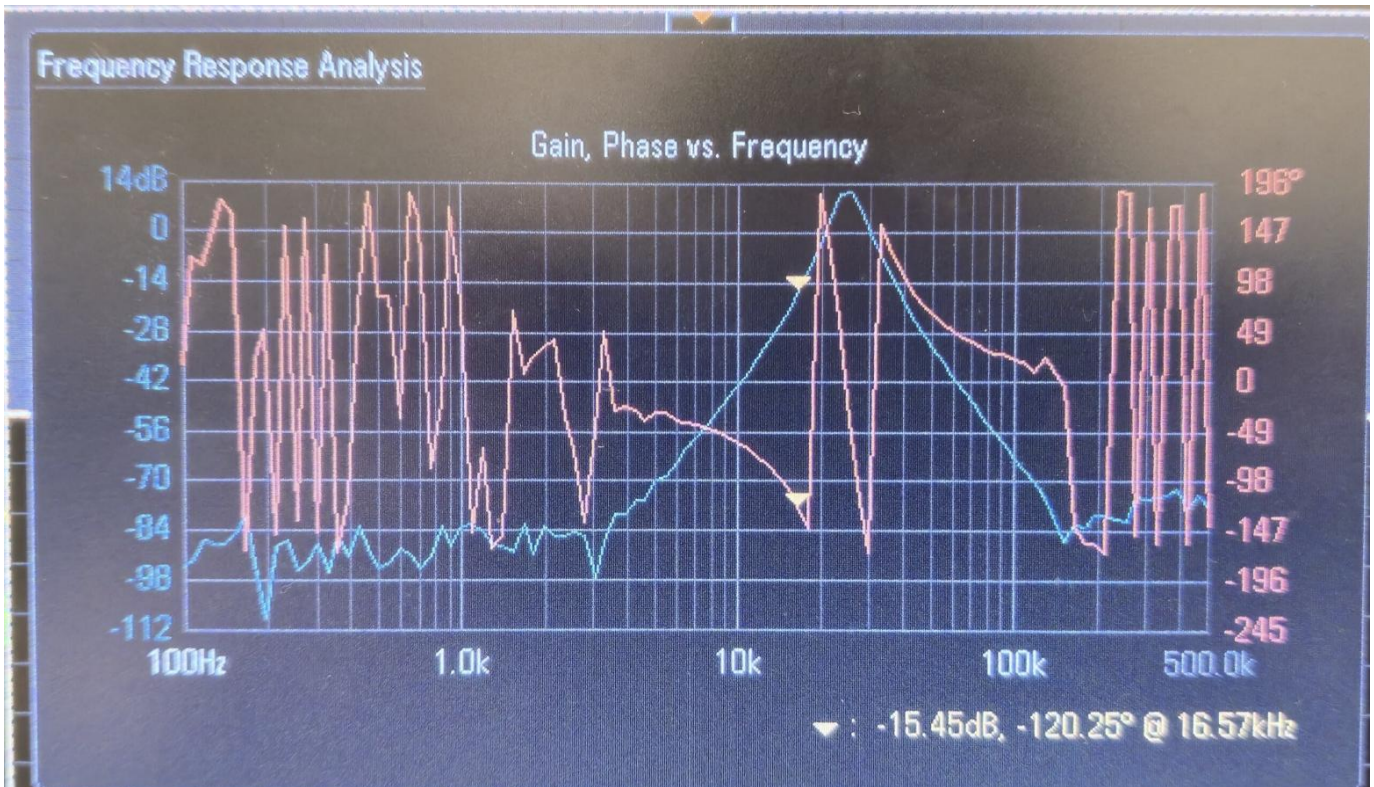

Peak Detector Response (25 kHz Function Generator Input)

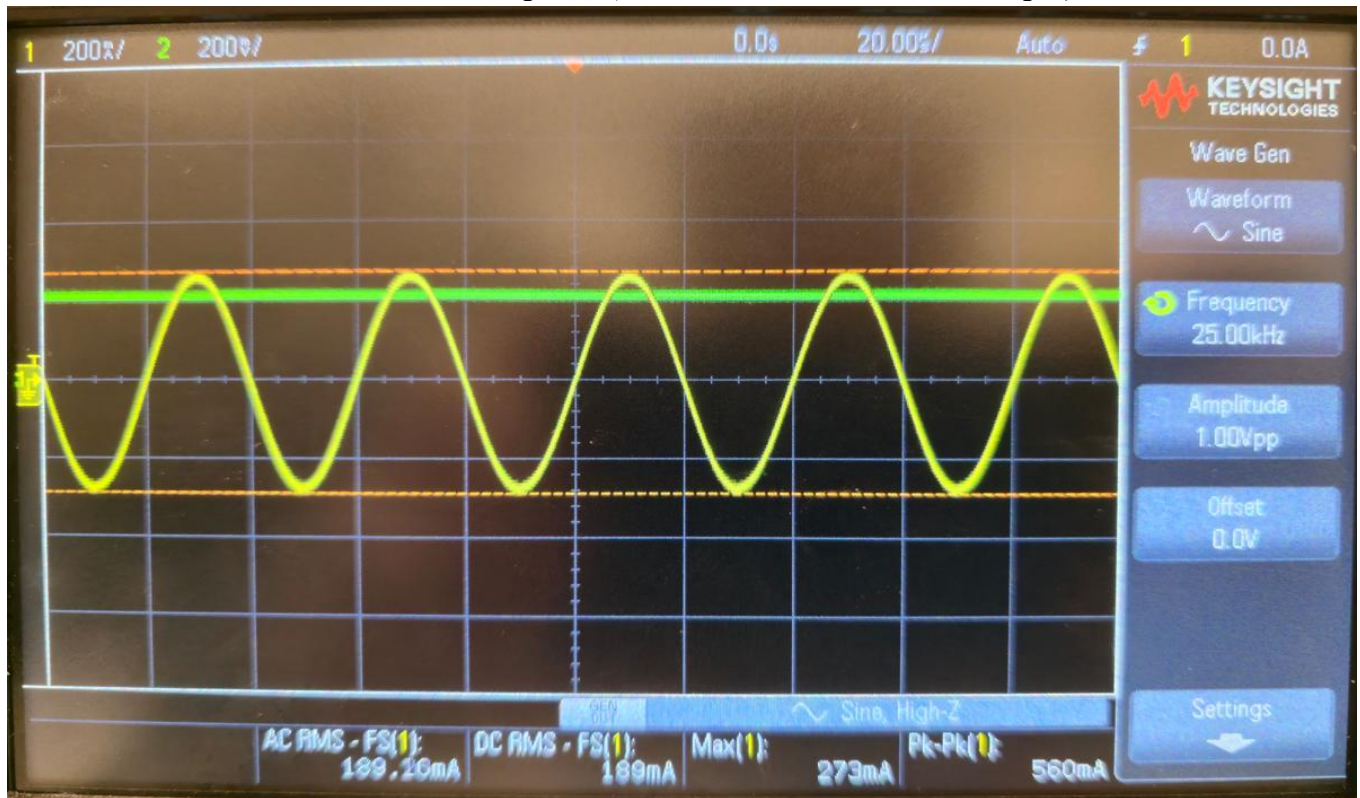

Peak Detector Response (17 kHz Function Generator Input)

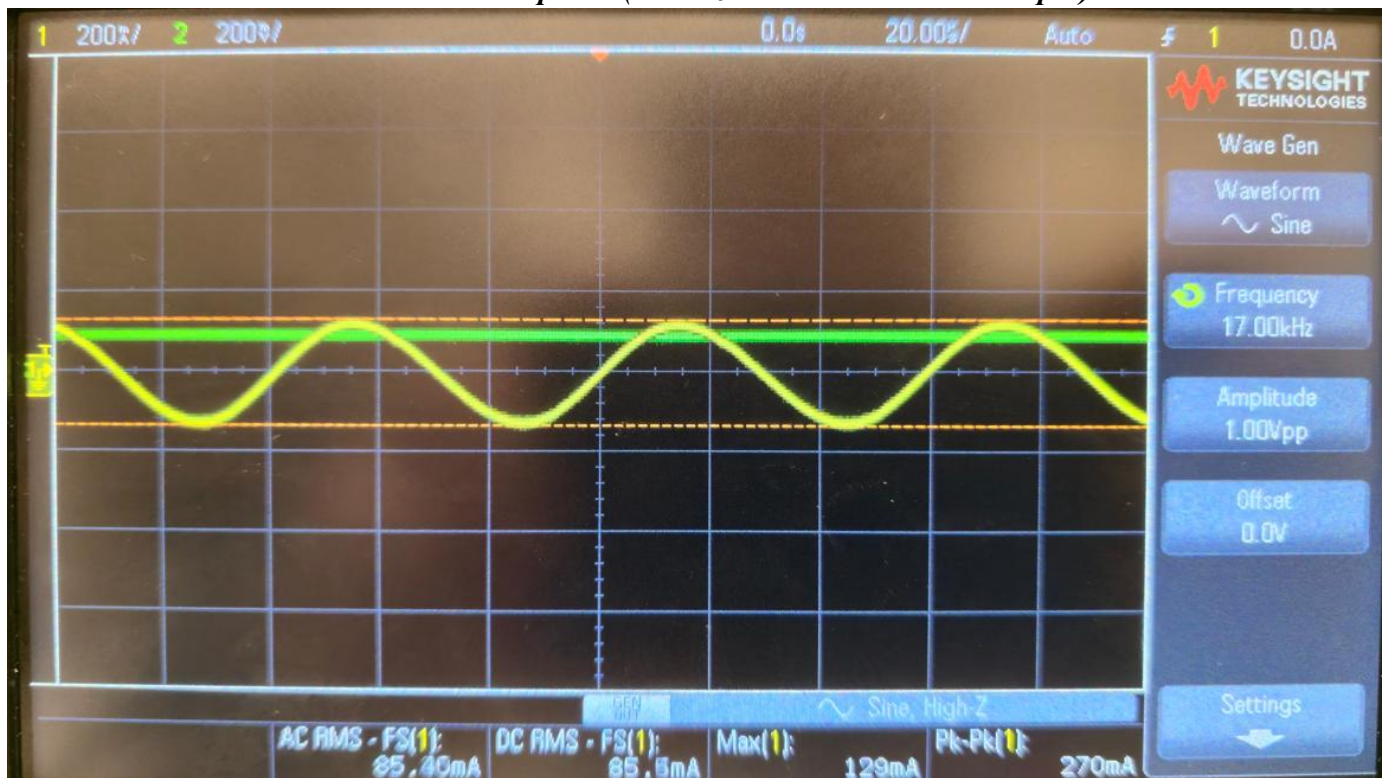

System Response to 25 kHz IR Signal

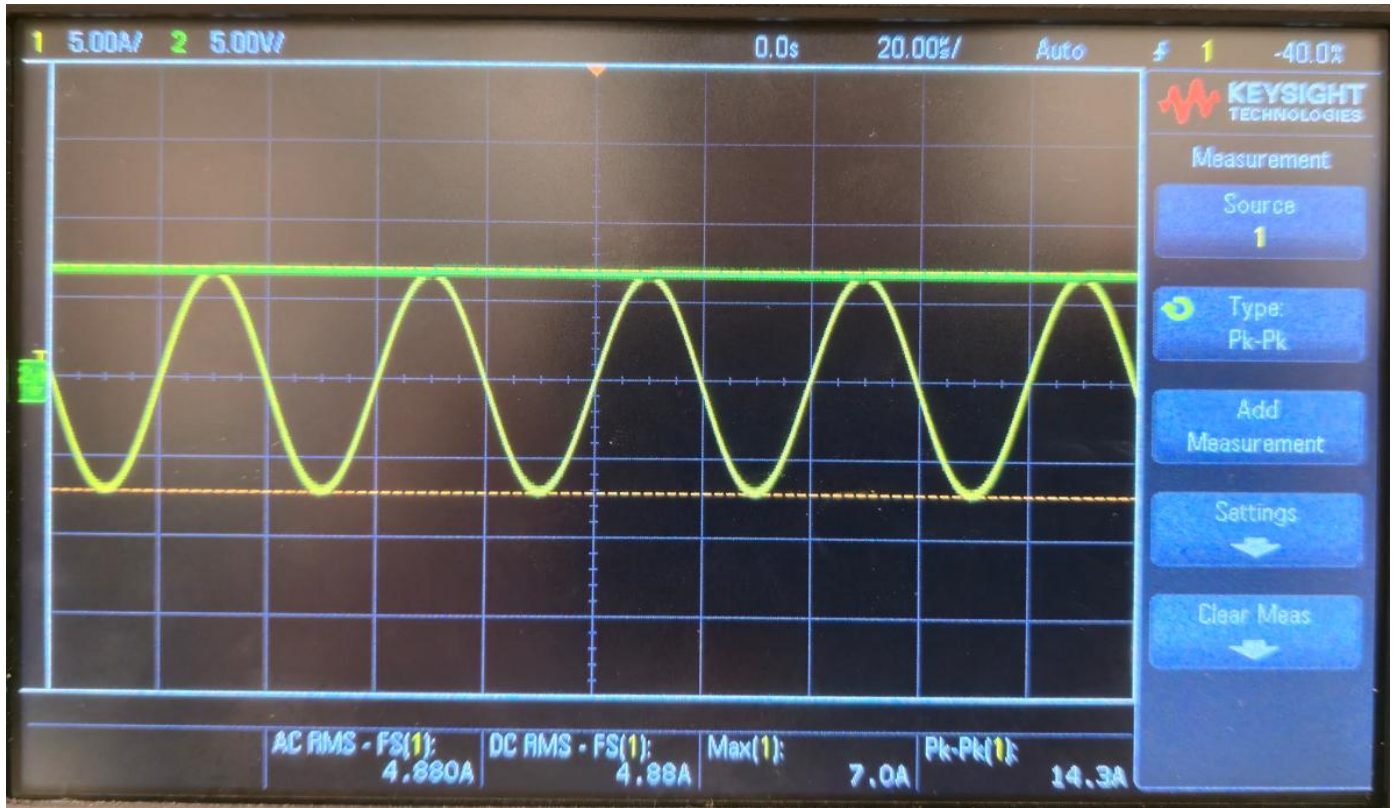

System Response to 17 kHz IR Signal

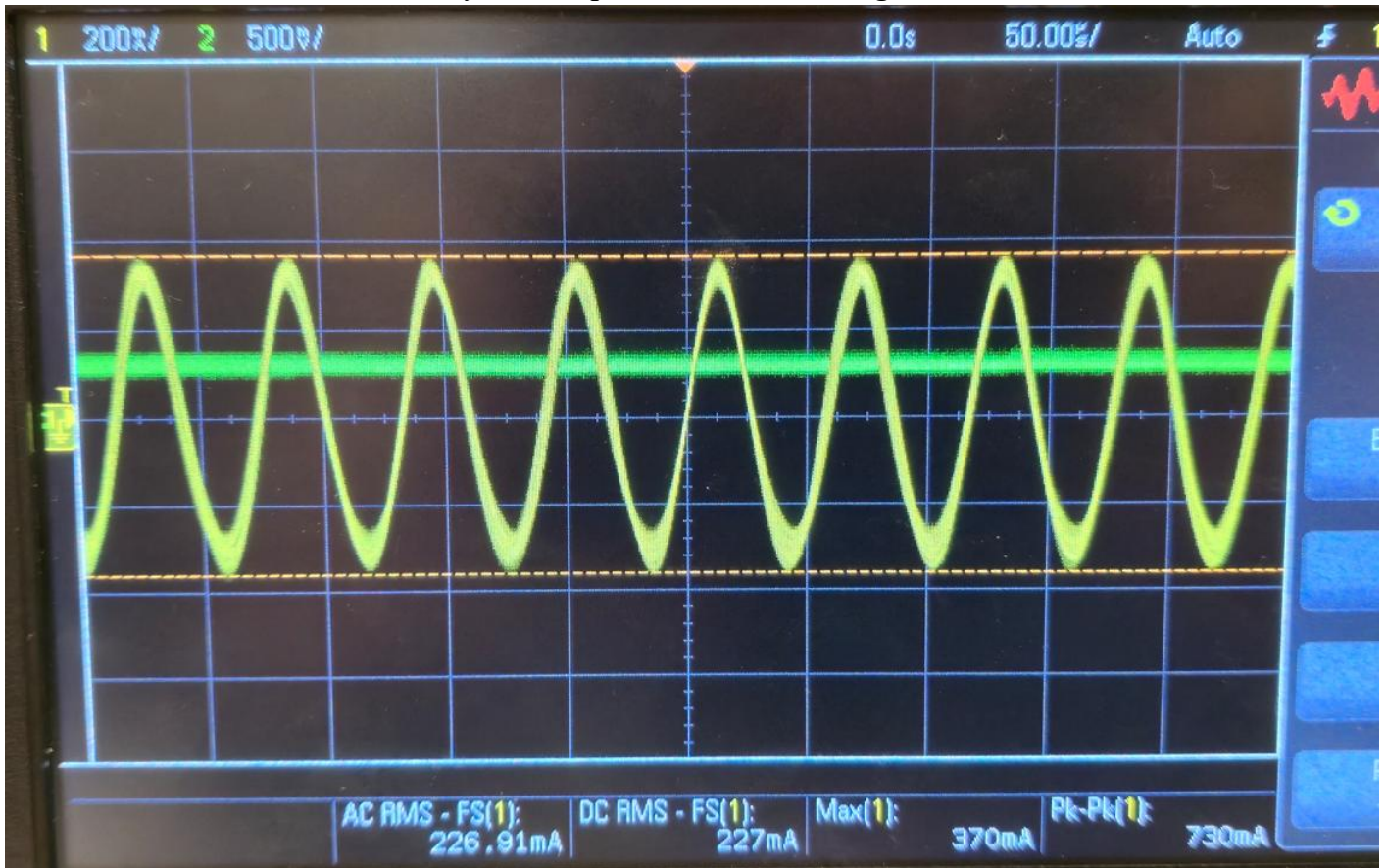

Verification Discussion

The quantitative and qualitative results verify that the standalone 25 kHz filter operates as designed and meets all project requirements. As shown in the data tables, the theoretical peak gain at 25 kHz (8.34 dB) closely matches the LTspice simulation (8.69 dB). The measured lab gain of 12.25 dB provides robust amplification of the target frequency.

Crucially, the circuit successfully rejects adjacent frequencies. At 17 kHz, the measured attenuation was -15.45 dB, creating a massive 27.7 dB separation between the 25 kHz target signal and the 17 kHz noise. Qualitatively, the video demonstration confirms this mathematical separation is highly effective: the indicator LED reliably illuminates only when the 25 kHz signal is applied and remains off during steady 17 kHz or 10 kHz signals. It should be noted that a brief, momentary LED flash occurs when the 17 kHz signal is initially turned on; this is an expected transient response caused by the abrupt voltage step generating broad-spectrum harmonics that briefly ring through the 25 kHz passband before the filter settles into its steady-state attenuation.